

## SECTION 7

### SPECIFICATIONS FOR PUMP STATIONS AND FORCE MAINS

#### **7.01 DESCRIPTION OF WORK**

##### 7.01.01 PUMP STATIONS DESCRIPTION OF WORK

All pump stations will be designed by the Township's Engineer.

##### 7.01.02 FORCEMAIN DESCRIPTION OF WORK

The Work shall consist of furnishing and installing force main of the specified size or sizes at the depths shown on the plans or specified herein, and furnishing all fittings and joint material, labor, materials, tools, and equipment for receiving, unloading, transporting, laying, and testing of force main pipe and fittings. Contractor shall furnish all necessary accessories to complete the pipe work as shown on the plans and specified herein.

#### **7.02 MATERIALS**

All materials furnished by the Contractor shall conform to the specifications which follow. Where reference specifications are mentioned the current edition or latest issue shall be used.

##### 7.02.01 Pipe

###### 7.02.01.01 Ductile Iron Pipe

Ductile iron pipe shall conform to the requirements of AWWA C-151 (ANSI A21.51). Ductile iron pipe shall be Class 52 unless otherwise specified. Brass wedges are required for all push on joints

###### 7.02.01.02 Fittings

All fittings shall be ductile iron in accordance with AWWA C-153 (ANSI A21.53). Fittings sixteen (16) inches in diameter and smaller shall have a minimum pressure rating of 350 psi.; fittings larger than sixteen (16) inches in diameter shall have a minimum pressure rating of 250 psi.

###### 7.02.01.03 Joints

Unless otherwise specified, all pipe joints shall be rubber gasket joints conforming to the requirements of AWWA C-111 (ANSI A21.11) for bolted mechanical joints or push-on joints. Joints on fittings shall be bolted mechanical joints.

7.02.01.04 Cement Lining

All pipe and fittings shall have Protecto 401 ceramic epoxy lining conforming to the requirements of AWWA C-104 (ANSI A21.4)

7.02.01.05 Plastic Wrap for Pipe

Where indicated on the Plans, or in the Specifications, the pipe shall be encased in a seamless polyethylene tube, in accordance with AWWA C-105 (ANSI A21.5). The ends of adjacent sections of polyethylene tubing shall be overlapped a minimum of one (1) foot, and the joint taped or otherwise secured to prevent displacement during backfill operations.

7.02.02 High Density Polyethylene (HDPE)

Force main pipe and fittings shall be DIPS/ IPS HDPE DR11 rated for a minimum pressure rating of 200 psi. Force main material shall conform to the following.

The pipe and fittings shall be made from resin with a cell classification of PE 44557C, and the pipe shall be labeled PE4710. The resin shall meet ASTM D 3050-05. The pipe shall also meet ANSI/AWWA C 906-2006 standard for polyethylene pipe and fittings. The pipe shall contain no recycled compounds except that generated in the manufacturer's own plant from resin of the same specification from the same raw material. The pipe shall be homogeneous throughout and free of visible cracks, holes, foreign inclusions, voids, or other injurious defects.

Fittings shall be butt-fused in accordance with ASTM D3261 before installation in the trench. Fusion in the trench shall be by butt fusion method. Electrofusion fittings shall not be allowed unless approved otherwise by the Township. Flange adapters shall be same pressure rating as the pipe and shall include all materials required for a sealed connection, including bolts.

Two tracer wires shall be placed with the pipe in the trench. Tracer wire shall be #12 AWG high strength locator wire with a minimum break load of 1150 lbs. Protective coating shall be a minimum of 45 mil High Molecular Weight, High Density Polyethylene (HMW-HDPE). Wire connectors shall be water tight and shall be provided for electrical continuity. The tracer wire shall be affixed to marker posts with a test station as required by the Township.

Testing of the tracer wire by the use of a typical low frequency (512 HZ or similar) line locating equipment will be required, and shall be witnessed by the owner. Continuity testing of the tracer wire system in lieu of using locating equipment shall not be accepted.

The Marking Post shall be a Rhino TriView™ Marking System post or approved equal and shall be colored green with the Force Main label. The test station shall be similar to Rhino TriView™ or approved equal and shall be supplied at termination of tracer wire locations. The post shall be buried per the manufacturer's recommendations.

Tracer wire shall terminate at a marking post test station on each end. The location of each marking post and test station shall be coordinated with the Owner's Engineer and Township prior to placement.

7.02.03 Valves

All resilient seated gate valves shall be ductile iron and conform to AWWA C-509, or AWWA C-515, Standards for Gate Valves for Water and Sewerage Systems. The valves shall be fully bronze mounted and shall be furnished with O-ring packing. The direction of the opening shall be left or counterclockwise. Bolts and nuts shall be stainless steel.

Valves shall be Traverse City Iron Works, EJ, Clow Corporation R/W Resilient Wedge, Waterous Resilient Wedge, U.S. Pipe Metroseal 250, or equal.

All valves 16" and larger shall be equipped with totally enclosed bevel gear operator, unless otherwise approved by the Township.

Valve nut extensions shall be supplied at no additional cost to the Owner when the height of the valve box exceeds the Township's equipment. The Township uses 8 foot long valve wrenches. When valve nut extensions are provided, they shall be permanently affixed to the valve nut with a non-corrosive device such as a bolt or pin and cotter key; set screws will not be approved.

**7.03 HANDLING OF MATERIAL**

The Contractor shall use care and proper equipment during the unloading and distribution of force main materials on the job site to insure the materials are not damaged.

Pipe and/or fittings shall not be rolled or skidded off the truck beds against previously unloaded materials.

**7.04 ALIGNMENT AND GRADE**

7.04.01 General

The force main shall be laid and maintained to the required lines and grades with fittings at the required locations.

7.04.02 Deviations Occasioned by Other Structures

Whenever obstructions not shown on the Plans are encountered during the progress of the Work and interfere to such an extent that an alteration in the Plans is required, the Township shall have the authority to change the Plans and order a deviation from the line and grade or arrange with the owners of the structures for the removal, relocation, or reconstruction of the obstructions.

7.04.03 Depth of Pipe

All pipe shall be laid with the top of the pipe a minimum depth of five (5) feet below established street centerline grade, and with a minimum cover of five (5) feet below existing grade at the force main, unless specified otherwise.

**7.05 LAYING**

7.05.01 Lowering of Force Main Material Into Trench

Proper implements, tools, and facilities shall be provided and used by the Contractor for the safe and expedient completion of the work. All pipe and fittings shall be carefully lowered into the trench by means of suitable tools or equipment, in such a manner as to prevent damage to force main material and protective coatings and linings. Under no circumstances shall force main materials be dropped or dumped into the trench.

If damage occurs to any pipe or fittings in handling, the damage shall be immediately brought to the Township's attention. The Township shall prescribe corrective repairs or rejection of the damaged items.

7.05.02 Inspection Before Installation

All pipe and fittings shall be carefully examined for cracks and other defects while suspended above the trench immediately before installation in final position. Spigot ends shall be examined with particular care as this area is the most vulnerable to damage from handling. Defective pipe or fittings shall be laid aside for inspection by the Township, who will prescribe corrective repairs or rejection.

7.05.03 Cleaning of Pipe and Fittings

All lumps, blisters, and excess coating shall be removed from the bell and spigot ends of each pipe, and the outside of the spigot and the inside of the bell shall be wire brushed and wiped clean and dry and free from oil and grease before the pipe is laid.

7.05.04 Laying of Pipe

All dirt or other foreign material shall be removed from the inside of the pipe before it is lowered into its position in the trench, and it shall be kept clean by approved means during and after laying. No tools or other articles shall be stored in the pipe at any time.

For ductile iron pipe each length of pipe is placed in the trench, the spigot end shall be centered in the bell and the pipe forced home and brought to correct line and grade. The pipe shall be secured in place with approved backfill material tamped under it except at the bells. Precautions shall be taken to prevent dirt from entering the joint space.

At times when pipe laying is not in progress, the open ends of the pipe shall be closed by a watertight plug or other means approved by the Township. This provision shall apply during the noon hour as well as overnight. If water is in the trench, the seal shall remain in place until the trench is pumped completely dry.

7.05.05 Bell Ends to Face Direction of Laying

Ductile Iron Pipe shall be laid with bell ends facing in the direction of laying, unless directed otherwise by the Township. Where pipe is laid on a grade of ten (10%) percent or greater, the laying shall start at the bottom and shall proceed upward with the bell ends of the pipe upgrade.

**7.06 JOINING OF MECHANICAL - JOINT PIPE**

7.06.01 General Requirements

The general requirements in Sections 7.04 - 7.05 inclusive shall apply except that, where the terms “bell” and “spigot” are there used, they shall be considered to refer to the bell and spigot ends of the lengths of mechanical-joint pipe.

7.06.02 Cleaning and Assembly of Joint

The last eight (8) inches outside of the spigot and inside of the bell of mechanical joint pipe shall be thoroughly cleaned to remove oil, grit, excess coating, and other foreign matter from the joint and then coated with a lubricant as supplied or recommended by the pipe manufacturer and approved by the Township. The retaining gland (as referenced in section 7.08) shall then be slipped on the spigot end of the pipe with the lip extension of the gland toward the socket, or bell, end. The rubber gasket shall be coated with lubricant and placed on the spigot end with the thick edge toward the gland.

7.06.03 Bolting of Joint

The entire section of the pipe shall be pushed forward to seat the spigot end in the bell. The gasket shall then be pressed into place within the bell; care shall be taken to locate the gasket evenly around the entire joint. The retaining gland shall be moved along the pipe into position for bolting, all of the bolts inserted, and the nuts screwed up tightly with the fingers. All nuts shall be tightened with a suitable (preferably torque-limiting) wrench. The torque for various sizes of bolts shall be as follows:

<u>Size</u> Inches	<u>Range of Torque</u> Foot - Pounds
5/8	45 - 60
3/4	75 - 90
1	100 - 120
1-1/4	120 - 150

Nuts spaced 180 degrees apart shall be tightened alternately in order to produce an equal pressure on all parts of the gland. When tightening bolts, it is essential that the gland be brought up toward the pipe flange evenly, maintaining approximately the same distance between the gland and the face of the flange at all points around the socket. This may be done by partially tightening the bottom bolt first, then the top bolt, next the bolts at either side, and last, the remaining bolts. Repeat this cycle until all bolts are within the above range of torques. If effective sealing is not attained at the maximum torque indicated

above, the joint should be disassembled and reassembled after thorough cleaning. Over stressing of bolts to compensate for poor installation practice is not allowed.

Bolts shall be high strength, low alloy Cor-Blue bolts only conforming to ANSI/AWWA CIII/A21.11. Bolt manufacturer’s certification of compliance must accompany each shipment.

**7.06.04 Permissible Deflection in Mechanical-Joint Pipe**

Whenever it is desirable to deflect mechanical-joint pipe in order to form a long-radius curve, the amount of deflection shall not exceed the maximum limits shown in Table 1.

**TABLE 1  
PERMISSIBLE DEFLECTIONS IN MECHANICAL - JOINT PIPE**

Size of Pipe Inches	Max. Permissible Deflection Per Length - Inches		Approx. Radius of Curve Produced By Succession of Joints - Feet	
	18'	20'	18'	20'
3	31	35	125	140
4	31	35	125	140
6	27	30	145	160
8	20	22	195	220
10	20	22	195	220
12	20	22	195	220
14	13.5	15	285	320
16	13.5	15	285	320
18	11	12	340	380
20	11	12	340	380
24	9	10	450	500

**7.07 JOINING OF PUSH-ON JOINT PIPE**

**7.07.01 General Requirements**

The general requirements in Sections 7.04 - 7.05 inclusive shall apply except that, where the terms “bell” and “spigot” are there used, they shall be considered to refer to the bell and spigot ends of the lengths of push-on joint pipe.

**7.07.02 Cleaning and Assembly of Joint**

The inside of the bell and the outside of the spigot end shall be thoroughly cleaned to remove oil, grit, excess coating, and other foreign matter. The circular rubber gasket shall be flexed inward and inserted in the gasket recess of the bell socket.

A thin film of gasket lubricant shall be applied to either the inside surface of the gasket or the spigot end of the pipe or both. Gasket lubricant shall be as supplied or recommended by the pipe manufacturer and approved by the Township.

The spigot end of the pipe shall be centered in the bell and forced or pushed home. Smaller sizes of pipe can be pushed or forced into place by hand; larger sizes will require the use of mechanical assistance.

7.07.03 Permissible Deflection in Push-On Joint Pipe

Whenever it is desirable to deflect push-on joint pipe, in order to form a long radius curve, the amount of deflection shall not exceed the maximum limits shown in Table 2, unless recommended by the pipe manufacturer and approved by the Township.

7.07.04 Brass Wedges

All push-on joints shall have brass wedges. A minimum of two wedges shall be installed per joint for 12 inch diameter and smaller pipe; 3 wedges shall be used for greater than 12" diameter.

TABLE 2  
PERMISSIBLE DEFLECTIONS IN PUSH-ON JOINT PIPE

Size of Pipe Inches	Max. Permissible Deflection Per Length - Inches		Approx. Radius of Curve Produced By Succession of Joints - Feet	
	18'	20'	18'	20'
3	19	21	205	230
4	19	21	205	230
6	19	21	205	230
8	19	21	205	230
10	19	21	205	230
12	19	21	205	230
14	11	12	340	380
16	11	12	340	380
18	11	12	340	380
20	11	12	340	380
24	11	12	340	380

**7.08 ANCHORAGE**

**7.08.01 Anchorage for Plugs, Caps, Tees, Bends, and Valves**

Unless otherwise specified or approved by the Township, movement of all plugs, caps, tees, and bends shall be prevented by use of restrained joint pipe or joint restraining glands. Joint restraining glands shall not be used to provide restraint to plain end fittings.

**7.08.01.01 Restraint Joint Pipe**

The use of restrained joint pipe first shall be approved by the Owner. If approved, all ductile iron restrained joint pipe shall be Clow Corporation “Super-Lock”; American Ductile Iron Pipe “Lok-Ring Joint” or “Flex-Ring Joint”; or approved equal. All components of the restrained joint shall be as manufactured, supplied, or recommended by the manufacturer of the restrained joint pipe system actually installed.

**7.08.01.02 Joint Restraining Glands**

Joint restraining glands shall be EBBA Iron Sales “Megalug”, or approved equal. Joint restraining glands shall not be used to provide restraint to plain end fittings.

Bolts shall be high strength, low alloy Cor-Ten shear bolts only conforming to ANSI/AWWA CIII/A21.11. Bolt manufacturer’s certification of compliance must accompany each shipment.

When joints are to be restrained with mechanical devices as noted above, all joints shall be restrained for a minimum distance from the fitting as required in the following table.

**PIPE RESTRAINT LENGTH REQUIRED, FEET**

Pipe Diameter	Tees, 90° Bends	45° Bends	22-1/2° Bends	11-1/4° Bends	Dead Ends	Reducers (one size)	**
4"	23	9	5	2	57		
6"	32	13	6	3	82	43	63
8"	41	17	8	4	104	43	55
12"	58	24	12	6	149	80	120
16"	74	31	15	7	192	82	110
20"	89	37	18	9	233	82	104
24"	104	43	21	10	272	82	99
30"	123	51	25	12	328	115	148
36"	141	58	28	14	379	115	140

\*\*If the straight run of pipe on the small side of the reducer exceeds this value, then no restrained joints are necessary.



NOTE: The length of restrained joint pipe required as shown in the table above is based on trench backfill being compacted to ninety five (95%) percent of maximum unit weight in accordance with MDOT procedures. If the pipe is wrapped in polyethylene, a greater length of restrained pipe will be required as specified, shown on the Plans, or directed by the Township. A multiplier of 1.43 shall be used if the pipe is installed with polyethylene wrap.

All joints lying within the above minimum distances from the fitting must be restrained as noted herein.

Tees: Tees shall be restrained in the branch direction as required in the table above. Also, to augment the above, in the straight through direction, the minimum length of the first pipe on either side of the tee shall be ten (10) feet.

Bends: Bends shall be restrained in both directions as required in the table above.

7.08.02 Reaction Backing (Thrust Blocks)

Reaction backing (thrust blocks) shall be used only at locations indicated on the Plans, or approved by the Township.

Reaction backing shall be concrete of a mix not leaner than one (1) part cement to two and one-half (2-1/2) parts sand and five (5) parts stone, and having a compressive strength of not less than 2,000 psi after twenty eight (28) days. Backing shall be placed between solid ground and the fitting to be anchored. The area of bearing on the pipe and on the ground in each instance shall be that shown in the table below or directed by the Township. The backing shall, unless otherwise shown or directed, be so placed that the pipe and fitting joints will be accessible for repair.

REACTION BACKING

Minimum Bearing Area against undisturbed trench wall, in square feet, for sand is indicated in the table below. Details of placement are shown in Standard Details.

Pipe Size	Tees, Plugs, Wyes,		Wyes, 22-1/2° Els or Less
	45° Els	90° Els	
6"	3	3	1
8"	4	6	2
10"	7	9	3
12"	9	11	3
16"	13	20	6
20"	20	28	8
24"	28	40	11

Other Soil Conditions

Cement Sand or Hardpan	-	multiply above by 0.5
Gravel	-	multiply above by 0.7
Hard Dry Clay	-	multiply above by 0.7
Soft Clay	-	multiply above by 2.0

Muck-secure all fittings with restrained joint pipe or joint restraining glands, with concrete reaction backing the same as listed for sand conditions.

**7.09 CLEAN OUTS**

Single and double clean outs shall be constructed as shown on the standard detail. All pipe and fittings for the clean out shall be ductile iron, unless otherwise approved by the Township. All ductile iron pipe and fittings used shall have Protecto 401 ceramic epoxy lining.

For HDPE, when approved by the Township, all pipe and fittings as part of the cleanouts shall be HDPE DR 11 rated pipe apart from the ductile iron cap attached to the top of each cleanout mechanical joint (MJ) adapter.

As DR11 HDPE fabricated wye fittings have de-rated pressure ratings (< 200 psi), wye fittings shall be over-wrapped to an operating pressure rating equal to 200 psi, equal to the mainline DR11 pressure rating of the mainline force main.

Unless otherwise specified, manhole castings shall be East Jordan No. 1045 with 1040A cover or approved equal.

**7.10 AIR RELEASE AND VACUUM RELIEF VALVES**

**7.10.01 Air Release and Vacuum Relief Valve**

Combination Air release/vacuum relief valve shall operate under pressure and allow entrapped air and gases to escape from the pipeline. Valves shall be manufactured in compliance with ANSI/AWWA C512 for wastewater service. The make and model shall be review and approved by the Township

The valve shall have a flanged inlet connection, stainless steel body, stainless steel shaft, stainless steel float and trim, and NBR seat. The valve shall be supplied with backflushing attachments so that the interior body can be flushed periodically for proper operation. Valves shall have a two year warranty.

Valves shall be as specified in the Project specifications.

**7.10.02 Air Release and Valve Relief Manhole**

Air release and vacuum relief manholes shall be constructed in accordance with the details as shown on the Project construction drawings.

Precast bases shall be installed on the subbase in such a way as to provide a uniform bearing under the manhole base.

Precast manholes with integral bottom may be used; however, any changes to the structure due to minor field adjustments in alignment and grade required to meet construction conditions shall be made by the Contractor.

## **7.11 HYDROSTATIC TEST**

### **7.11.01 Procedure**

All tests will be made by the Contractor using the Contractor's own equipment, operators, and supervision, in the presence of the Township or its duly authorized representative. The length of the section to be tested shall be as approved by the Township, or as shown on the Plans.

### **7.11.02 Air Removal Before Test**

Before applying the specified test pressure, all air shall be expelled from the pipe. If permanent air vents are not located at all high points, the Contractor shall install corporation cocks at such points so the air can be expelled as the line is filled with potable water. After all the air has been expelled, the corporation cocks shall be closed and the test pressure of 150 psi applied.

### **7.11.03 Leakage Test – Ductile Iron Pipe**

A leakage test shall be conducted in the presence of the Township after the pressure test has been satisfactorily completed. The Contractor shall furnish the pump, pipe, connections, gages, and all other necessary apparatus, and shall furnish the necessary assistance to conduct the test. The duration of each leakage test shall be two (2) hours and during the test the main shall be subjected to a pressure of 150 psi. When several valved sections are tested as one test, the maximum allowable leakage will be equivalent to the calculated smallest value of the maximum allowable leakage for any valved section.

No pipe installation will be accepted if the leakage is greater than that determined by the formula:

$$L = \frac{SD\sqrt{P}}{148,000}$$

Where:

L = Allowable leakage in gallons per hour

S = Length of pipe tested, in feet

D = Nominal diameter of the pipe, in inches

P = Average test pressure during the leakage test, in pounds per square inch gage.

This formula is based on allowable leakage of 10.49 gallons per day, per mile of pipe, per inch of nominal diameter at 150 psi.

The Township shall be furnished a written report of the results of the leakage test that identifies the specific length of pipe tested, the pressure, the duration of the test, and the amount of leakage. The report shall be signed by the Contractor and the Township.

#### 7.11.04 Hydrostatic Test – HDPE Pipe

Testing in the trench: fill the pipeline with water after it has been laid, bleed off any trapped air. Subject the lowest element in the system to a test pressure that is 1.5 times the design pressure or a minimum of 150 psi, whichever is greater, and check for any leakage. When, in the opinion of the Owner's Engineer, local conditions require that the trenches be backfilled immediately after the pipe has been laid, apply the pressure test after backfilling has been completed but not sooner than a time which will allow sufficient curing of any concrete that may have been used. Typical minimum concrete curing times are thirty six (36) hours for early strengths and seven (7) days for normal strengths.

The test procedures consist of two steps; the initial expansion and the test phase. When test pressure is applied to a water-filled pipe, the pipe expands. During the initial expansion of the pipe under test, sufficient make-up water must be added to the system at hourly intervals for three (3) hours to maintain the test pressure. After about four (4) hours, initial expansion should be complete and the actual test can start.

When the test is to begin, the pipe is full of water and is subjected to a constant test pressure of 1.5 times the system design pressure or 150 psi, whichever is greater. The test phase should not exceed three (3) hours, after which time any water deficiency must be replaced and measured. Add and measure the amount of make-up water required to return to the test pressure and compare this to the maximum allowance in Figure 22.

An alternate leakage test consists of maintaining the test pressure (described above) over a period of four (4) hours, and then dropping the pressure by 10 psi (0.069 MP's). If the pressure then remains within five (5%) percent of the target value for one (1) hour, this indicates there is no leakage in the system.

Note: Under no circumstances shall the total time under test exceed eight (8) hours at 1 ½ times the system pressure rating. If the test is not complete within this time limit (due to leakage, equipment failure, etc.), the test section shall be permitted to "relax" for eight (8) hours prior to the next test sequence.

ALLOWANCE FOR EXPANSION UNDER TEST PRESSURE  
US GALLONS/100 FEET OF PIPE

Nominal Pipe Size (Inches)	1 hour Test	2 Hour Test	3 Hour Test
3	0.10	0.15	0.25
4	0.13	0.25	0.40
6	0.30	0.60	0.90
8	0.50	1.0	1.5
10	0.75	1.30	2.10
11	1.0	2.0	3.0
12	1.1	2.3	3.4
14	1.4	2.8	3.2
16	1.7	3.3	5.0
18	2.2	4.3	6.5
20	2.8	5.5	8.0
22	3.5	7.0	10.5
24	4.5	8.8	13.3
28	5.5	11.1	16.8
32	7.0	14.3	21.5
36	9.0	18.0	27.0
40	11.0	22.0	33.0
48	15.0	27.0	43.0

\*These allowances only apply to the test period and not to the initial expansion phase.

7.11.05 Variation from Permissible Leakage

If any test of pipe laid discloses leakage greater than that specified above, the Contractor shall at the Contractor's own expense locate and repair the leaks until the leakage is within the specified allowance.

7.11.06 Time for Making Test

The pipe may be subject to hydrostatic pressure and inspected and tested for leakage at any convenient time after the trench has been partially backfilled. Where any section of the main is provided with concrete reaction backing, the hydrostatic pressure test shall not be made until at least five (5) days have elapsed after the concrete reaction backing was installed. If high-early-strength cement is used in the concrete reaction backing, the hydrostatic pressure test will not be made until at least two (2) days have elapsed.

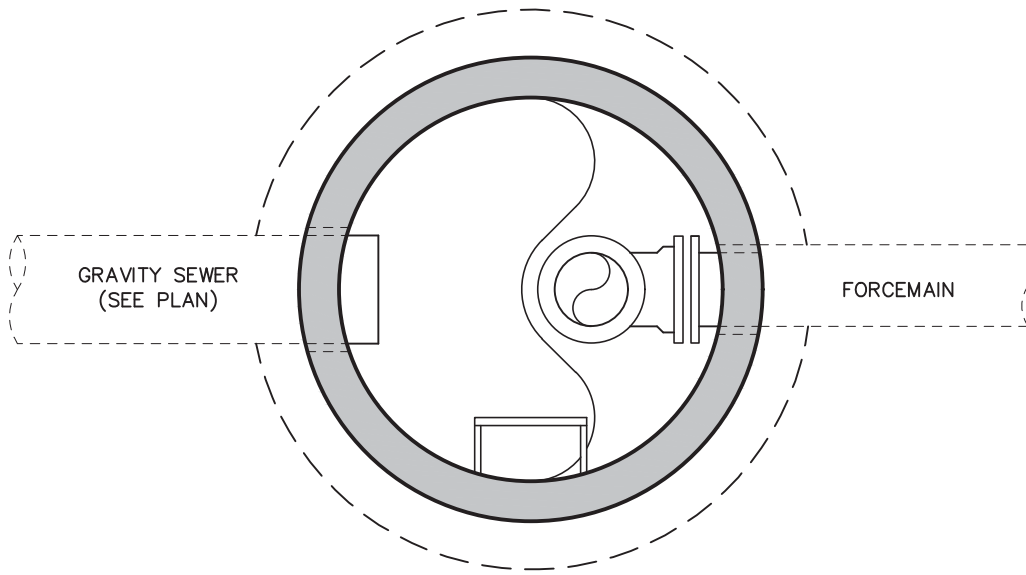

**PLAN VIEW**

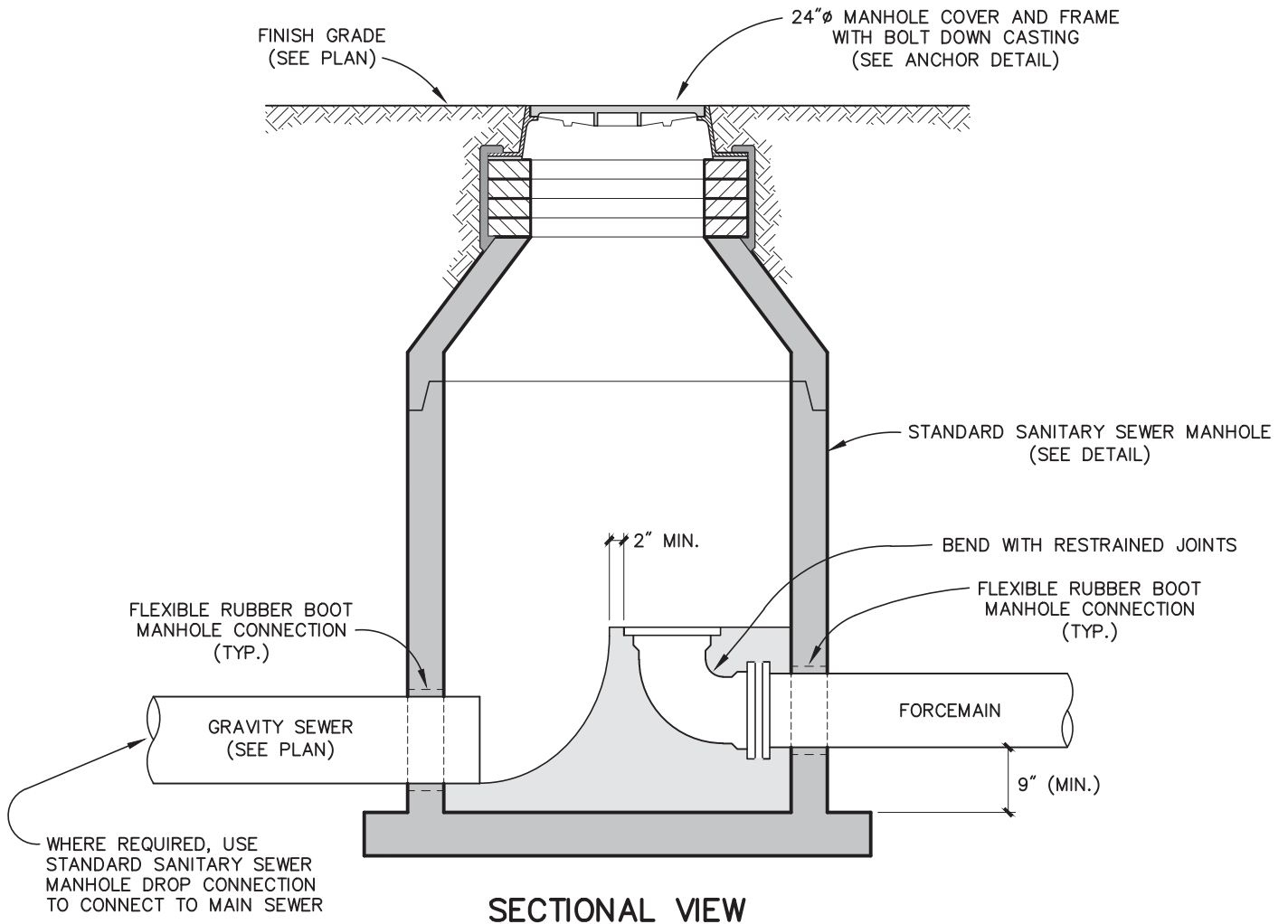

**SECTIONAL VIEW**

**STANDARD FORCE MAIN  
DISCHARGE MANHOLE**

T:\DWG\PROJECTS\2021\210111\JCT\_SPECIFICATION DRAWINGS\1. PRO\SECTION 7 - FORCEMAIN\7-14.FIN DISCHARGE MANHOLE - HSWITH - Apr. 13, 2022 - 08:20am - FredMehner

WHERE REQUIRED, USE  
STANDARD SANITARY SEWER  
MANHOLE DROP CONNECTION  
TO CONNECT TO MAIN SEWER



04/2022

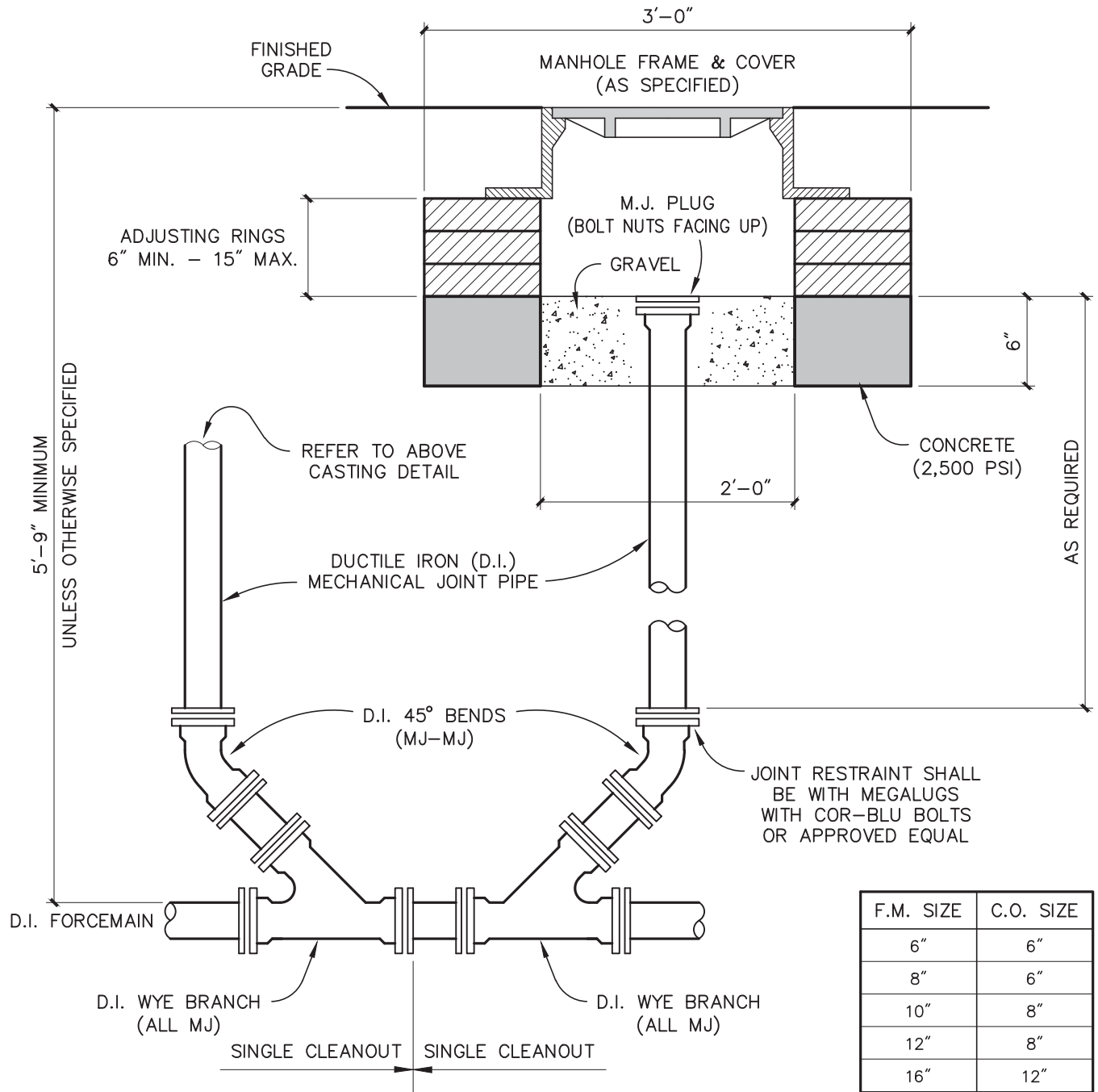

F.M. SIZE	C.O. SIZE
6"	6"
8"	6"
10"	8"
12"	8"
16"	12"
OVER 16"	12"

## STANDARD DOUBLE CLEAN OUT

(DUCTILE IRON FORCEMAIN)

### NOTE

1. ALL DUCTILE IRON PIPE AND FITTINGS SHALL BE COATED WITH PROTECTO-401 CERAMIC EPOXY LINING.
2. ALL CLEANOUTS SHALL HAVE MANHOLE FRAME AND COVER UNLESS OTHERWISE SPECIFIED.

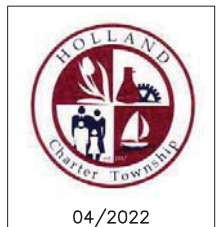

04/2022

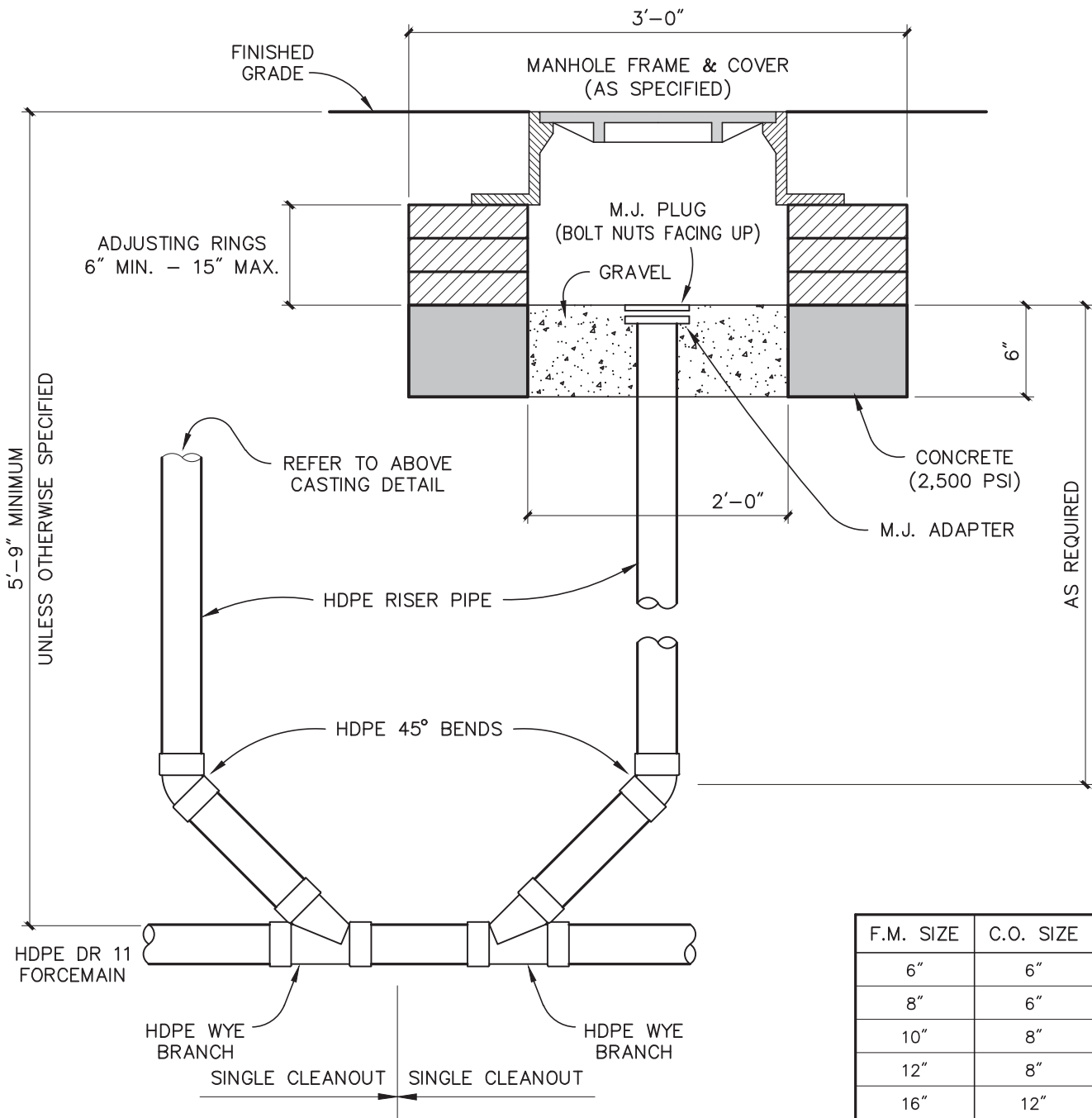

F.M. SIZE	C.O. SIZE
6"	6"
8"	6"
10"	8"
12"	8"
16"	12"
OVER 16"	12"

## STANDARD DOUBLE CLEAN OUT (HDPE FORCEMAIN)

### NOTES

1. ALL HDPE PIPE AND FITTINGS SHALL HAVE A PRESSURE RATING EQUAL TO OR GREATER THAN 200 PSI. IF FITTINGS ARE DE-RATED, FITTINGS MUST BE "WRAPPED" TO INCREASE PRESSURE RATING EQUAL TO OR GREATER THAN 200 PSI.
2. ALL CLEANOUTS SHALL HAVE MANHOLE FRAME AND COVER UNLESS OTHERWISE SPECIFIED.



T:\DWG\3D PROJECTS\2021\210111\JCT\_SPECIFICATION DRAWINGS\4\_PROD\SECTION 7 - FORCEMAIN\7-16\_FM\_DOUBLE\_CLEANOUT\_HDPE.DWG - WSM/TH - Apr. 13 2022 - 08:21am - Print/Replot